

ZOOMLION

ARTICULATING BOOM LIFT

ZA24J

Comply with CE Standard

HIGHLIGHTS

- ▶ Provide a work height of 26.23m, horizontal outreach of 18.9m, up and over height of 9.29m, and lift capacity of 250kg for higher efficiency
- ▶ Build-in multiple pressure control leveling system to enhance stability
- ▶ Precise load sensing system to improve overload safety operations
- ▶ Platform fast lifting function provides high-efficient performance without tower boom operation
- ▶ Outstanding below ground reach of 5.1m

FEATURES

Standard Features

Horn
All motion alarm
Proportional control
Self-closing entry gate
Flashing beacon
Auto-leveling system
Emergency stop button
Over tilt protection system
Emergency descent system
On-board diagnostic system
Oscillating axle
4.3' LED display
Load sensing system
Swing-out engine tray

Accessories & Options

- ▶ Platform work lights
- ▶ Anti-collision device
- ▶ AC power to platform

ACCESS WITH ZOOMLION GREEN

Phone: 0086(731)-88353692
E-mail: awp@zoomlion.com

Add: 701 Xulong Nan Lu, Xiangjiang New District, Changsha Hunan, China
Web: www.zoomlion-access.com

ZOOMLION

Model	ZA24J	
	Imperial	Metric
Size		
Work Height	86ft 1in	26.23m
Platform Height	79ft 6in	24.23m
Horizontal Outreach	62ft	18.9m
Up and Over Height	30ft 6in	9.29m
A - Stowed Length	36ft 12in	11.27m
B - Stowed Width	8ft 2in	2.49m
C - Stowed Height	9ft 3in	2.82m
D - Platform Length	8ft	2.44m
E - Platform Width	2ft 12in	0.91m
F - Wheelbase	10ft	3.05m
G - Ground Clearance	1ft 5in	0.42m
Performance		
Platform Capacity	550 lb	250kg
Drive Speed	3.11 mph	5.0km/h
Gradeability	45%(24°)	
Axles Oscillation	8in	0.2m
Turning Radius (Inside)	10ft 4in	3.14m
Turning Radius (Outside)	21ft 3in	6.48m
Turntable Swing	360° continuous	
Platform Rotation	±90°	
H-Tail Swing	3ft 4in	1.022m
Max. Working Slope	4°	
Max. Wind Speed	28mph	12.5m/s
Power		
Diesel Engine	Cummins QSF2.8 54kw/2400rpm Kubota V2607 55.4kw/2700rpm	
Fuel Tank Capacity	39.6 (us gal)	150L
Auxiliary Power	12V	
Control Voltage	12V	
Hydraulic System Capacity	63.4 (us gal)	240L
Hydraulic Tank Capacity	47.6 (us gal)	180L
Tire		
Type	15-625 Foam-filled Tires	
Weight		
Gross	39992 lb	18140kg

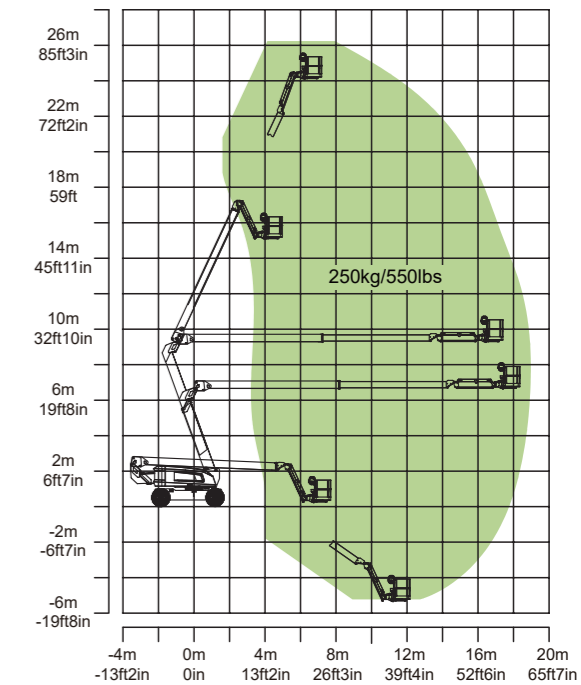
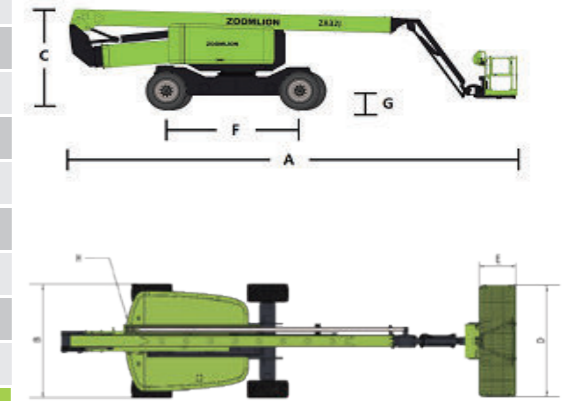

Range of Motion ZA24J