

ROUGH TERRAIN CRANE 90 T CAPACITY



WORKS FOR YOU.™

POWER IS IN YOUR HANDS

HIGH VERSATILITY

- 90 t lifting capacity
- 47,0 m max boom length with three boom telescoping modes
- 49,5 m max tip height main boom
- Additional 2-section jib of 9/ 17 m
- 66,0 m max tip height with jib

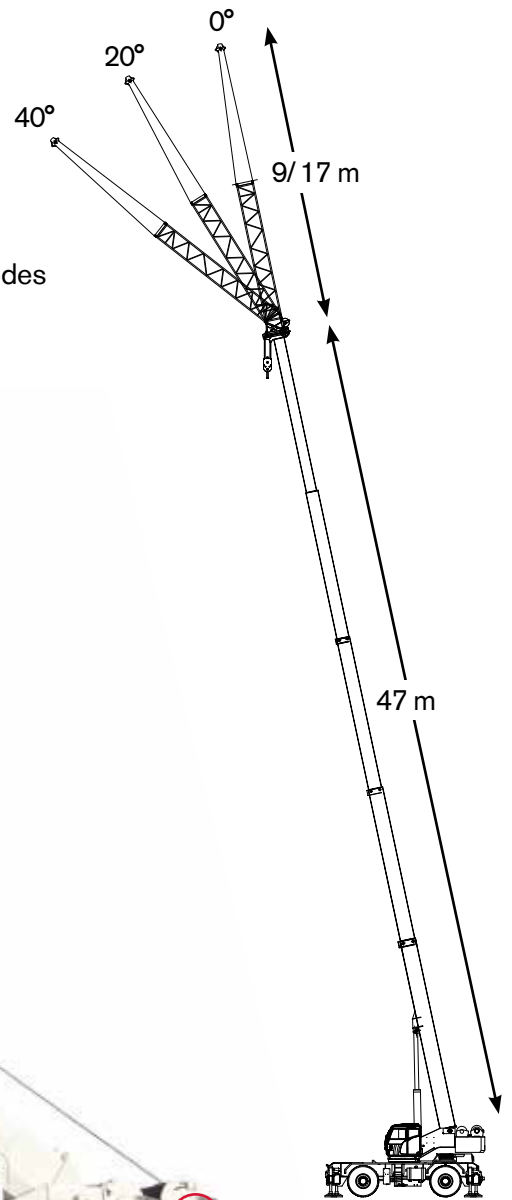

FULL CONTROL.

New TEOS Operating System

- 10" full-color touch screen display with intuitive interface
- Ergonomic electro-proportional joysticks with adjustable responsiveness to operator preferences

TOP CLASS EQUIPMENT

- T-Link Telematics included
- 3 working area LED lights outside the cab included

GREAT COMFORT, EXCELLENT VISIBILITY

- Extra wide and tiltable cabin with large glass surface. No blind spots.
- Integrated heating and air conditioning system

EASY TO HANDLE

- Easy to transport and maneuver
- Only 3 m width
- Four steering modes

WIDE RANGE OF OPTIONS

- Additional 2-section jib of 9/ 17 m and single sheave
- Auxiliary winch
- Up to 4 cameras for enhanced visibility, integrated on main display
- Radio remote control

WORKS FOR YOU.™

THE STRONGEST STRUCTURE DESIGNED FOR HEAVY LIFTS

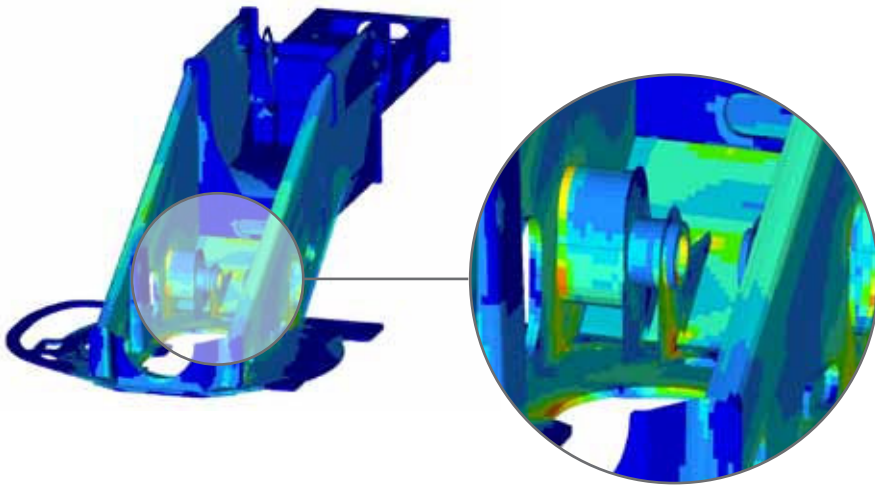

The strongest crane structure

Full crane structural and component FEM* analyses have been developed to deliver the best structural design, capable of delivering reliable performance, even in the most demanding applications.

*FEM: Finite Element Method

3 boom modes

The crane operator has the choice of three boom extension modes to meet different lifting needs.



Mode 1
Stability



Mode 2
Strength



Mode 3
Proportional

4 steering modes

For superior maneuverability around the jobsite, the crane offers 4 different steering modes.



2 wheel-front



2 wheel-rear



4 wheel-concentric



4 wheel-grab

HIGH POWER, LOW FUEL CONSUMPTION WITH IMPROVED ENGINE DESIGN

Cummins QSB6.7 Tier 4 Final/Stage V engine

The Cummins QSB6.7 Tier 4 Final/Stage V 6-cylinder engine delivers high-performance speed and hoisting capabilities. The new *anti-stall control* precisely controls power and speed to offer the lowest fuel consumption.

EcoMode: reduce fuel consumption

EcoMode employs automatic engine throttle to optimize power during crane operation and stand-by to lower fuel consumption.

WORKS FOR YOU.™

OPTIONAL 9/17 M JIB.

The TRT 90 features an optional 2-section jib with a 9 m lattice main section and 8 m secondary boxed section, providing a total length of 17 m. Jibs are stowed on the crane's side and easily attached to the main boom.

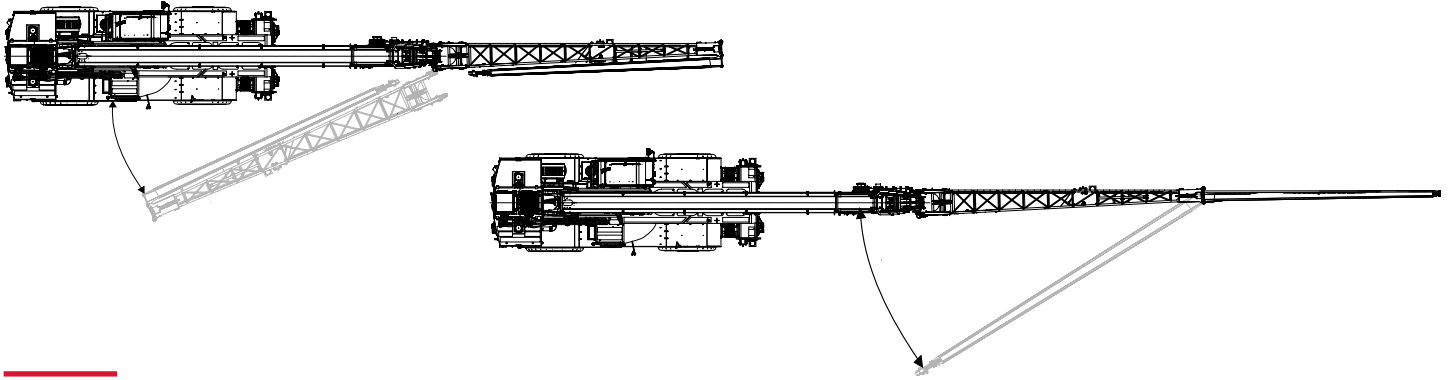

T-LINK TELEMATICS PLATFORM

The T-Link Telematics Platform, included on base unit, allows remote access of crane fleet operating data anytime, anywhere via the internet from your computer, smartphone or tablet.

- ▶ **Cost savings and increased of productivity**
Thanks to T-Link, cost savings and increased productivity can be achieved in all applications.
- ▶ **Better management of maintenance and technical assistance**
Remote monitoring delivers critical vehicle operating data and statistics. Routine maintenance can be scheduled more efficiently and unexpected issues are quickly addressed.
- ▶ **Fleet control**
Using the *Geofence* function, each crane's position is monitored, and the owner is notified in the event the crane leaves its set boundary.
- ▶ **Improved machine management, statistics and real-time data**
A wide range of *real-time operating data* and *fault-codes* are reported to assess fleet performance.
The machine's *Data logger* section collects detailed machine information, such as working hours, load lifting statistics, alarm history, etc.

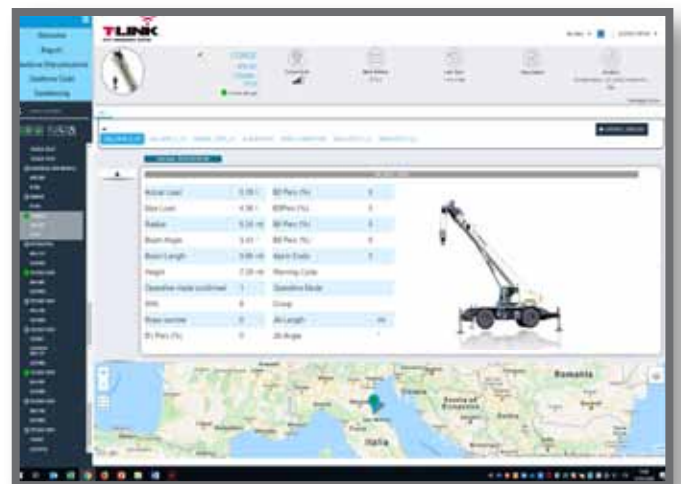

WORKS FOR YOU.™



TEOS NEW TEOS OPERATING SYSTEM



The new **Terex Operating System TEOS** offers improved information flow and accessibility to increase operating efficiency.

▶ **10" full-color touch screen display**

The new user interface with wide 10" full-color touch screen display features self-explanatory and intuitive icons.

▶ **Intuitive navigation**

Based on extensive customer feedback, information access is quick and easy. The primary and most frequently used functions are immediately accessible, and intuitive controls ensure a short learning curve for new crane operators.

▶ **Diagnostics**

Error messages and warnings are within easy view for enhanced safety. A dedicated menu for diagnostics gives immediate feedback on crane, main component and sensor operating status.

▶ **Options included**

Optional cameras are incorporated in the main display: the operator has full control of the crane from all points of view via a single display. Status of the radio remote control and T-Link platform options can also be seen on the main display.



Customizable electro-proportional joysticks

As desired, the operator can customize the buttons and fine-tune the responsiveness of all crane movements – smoother or prompt reaction – to meet personal preferences. Multiple personal configurations can be saved.

TEREX ROUGH TERRAIN CRANES

Terex Italia Srl

Via Cassoletta, 76 - Fraz. Crespellano
40053 Valsamoggia (BO)
Italy

Ph: +39 051 6501011

Email: mktg.cranes@terex.com



www.terex.com/rough-terrain-cranes



Brochure Reference: RT-BR-M-E-TRT 90-07/22

WORKS FOR YOU.™