

SENEBOGEN



129 kW (Stage V)



13.5 t



19 m



MULTICAB

624E

Heavy Duty Crawler Crane

Stage V

624E Advanced. The multifunction machine.



1969: First full hydraulic duty cycle crawler crane worldwide, SK 15

What makes up the E-Series

- 60 years of experience in the design and construction of duty cycle cranes
- Uncompromisingly high performance in all areas
- Technology that can be mastered: High-quality components without over-engineering
- Long service life and high value stability

Your top benefits:

1

Green Efficiency

Save fuel – reduce operating costs

Work quietly – protect operator and environment



2

Peak performance

Robust boom system – work on an incline of up to 4°

3

Maximum usability

Multicab – work in comfort

SENCON – work program selection made easy



4

Flexibility in service

Operate under full load – less space required

Strong undercarriage traction – good off-road capability

5

Easy transport

Mobile undercarriage with outrigger – ready to go in no time

6

Maintenance and service made easy

SENNEBOGEN control system – easy error diagnostics

Simple maintenance – clear labeling

7

Consultation and support in your area

3 production sites – 2 subsidiaries

130 sales partners – over 350 service stations

624E

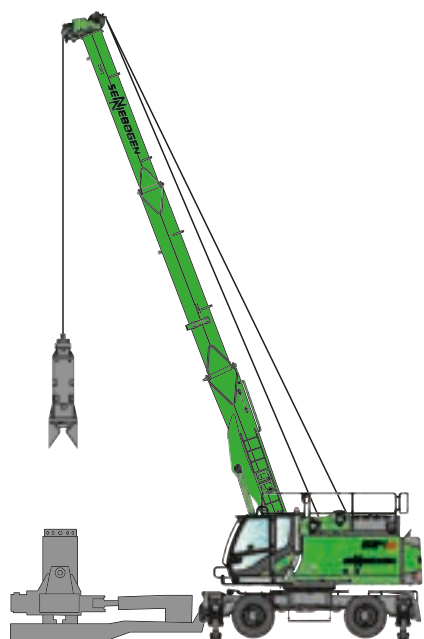

Casing oscillator

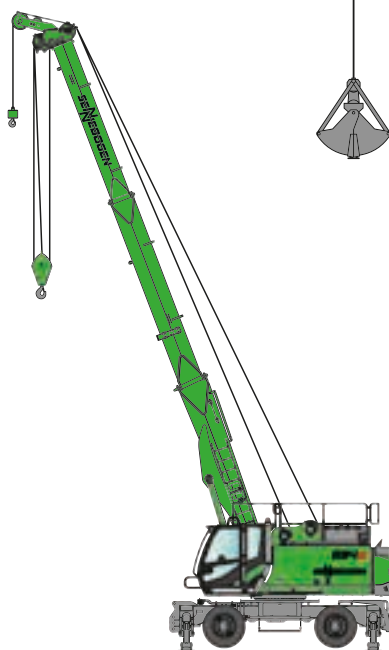

Crane equipment

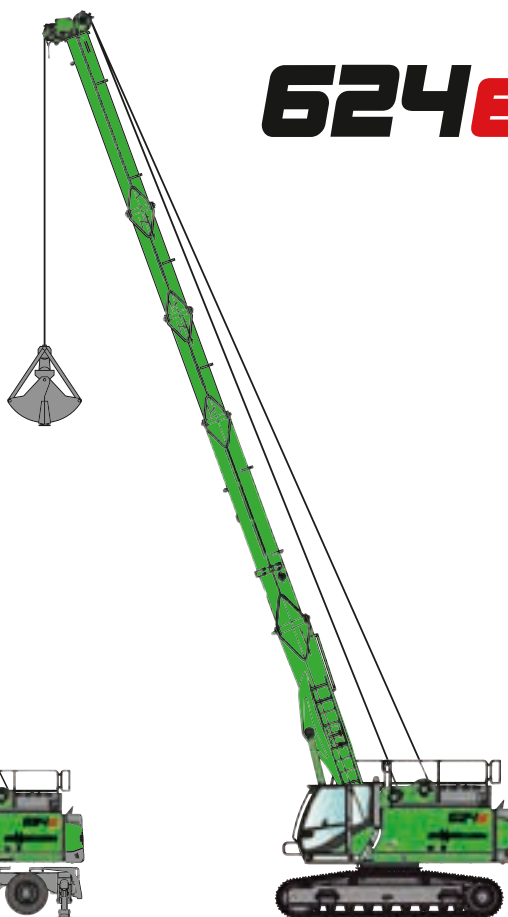

Grab equipment

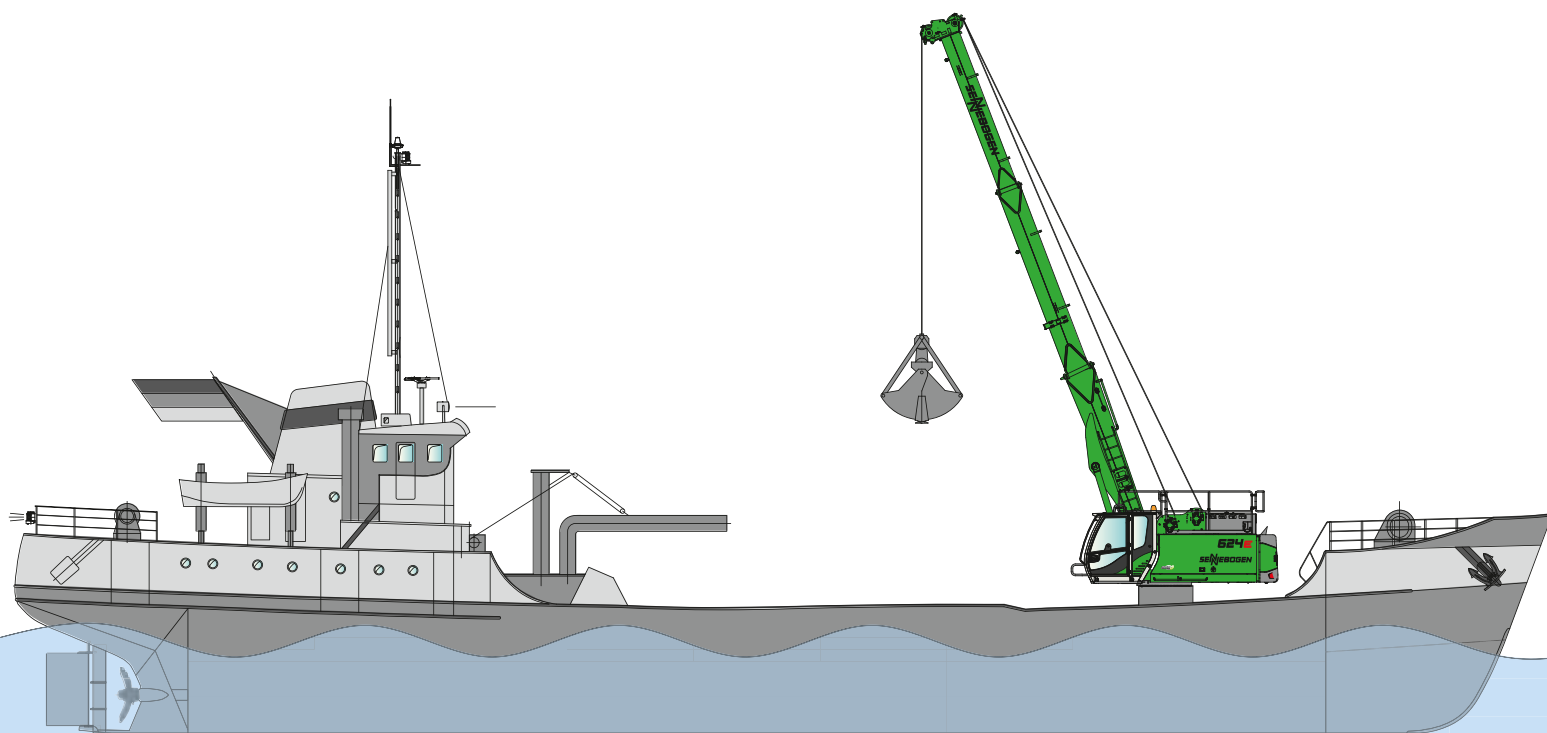

Ship construction

624E Technical data, equipment

MACHINE TYPE

Model (type) **624**

ENGINE

Power **129 kW / 175 PS at 2200 rpm**

Model **Cummins QSB 6.7 Stage V**
Direct injection, turbo-charged, charge air cooling, reduced emissions

Cooling Water-cooled

Air filter Dry filter with pre-separator, automatic dust discharge, main element and safety element, contamination indicator

Fuel tank **480 l**

DEF tank **38 l**

Electrical system **24 V**

Batteries **2 x 155 Ah**, main switch

UPPERCARRIAGE

Design Torsion-resistant box design, precision crafted, bronze bushings for boom bearing arrangement

Clear, service-friendly concept, engine installed in the longitudinal direction

Lighting LED headlights for optimal illumination of the work area

Safety Camera monitoring of the rear area and right side, uppercarriage rail

Options

- Maritime climate varnish as corrosion protection
- Low temperature package
- Fuel pump

HYDRAULIC SYSTEM

Multi-circuit hydraulic system for optimal function and capacity, all movements can be run simultaneously. The hydraulic pumps are variable displacement piston pumps with individual control and energy-saving flow-on-demand control. The pumps only supply as much oil as is actually consumed. Pressure cut-off, load limit sensing control.

Delivery rate Hydraulic circuit for winch 1 and driving
Hydraulic circuit for winch 2 and driving or support
Hydraulic circuit for slewing gear and boom adjustment

Operating pressure **max. 330 bar**

Hydraulic tank **310 l**

Options

- Bio-oil
- SENNEBOGEN HydroClean micro-filter system with water separator
- Potentiometer for casing machine and other attachments
- Grapple fill automation
- Hydraulic circuit for oscillation

SLEWING DRIVE

Gearbox Compact planetary gear with slant-axis hydraulic motor, integrated brake valves

Parking brake Spring-loaded multi-disk brake

Slewing ring Ball bearing rotary connection with interior gearing

Slewing speed 0 – 3,2 rpm, variable

CAB MULTICAB

Cab type Multicab

Cab equipment With air suspended comfortable cab with super sound insulation. All-weather version, all-round glazing made of safety glass and large roof window, adjustable windscreen. With air suspended comfortable seat, weight adjustable and vibration damped. Dashboard overview with swiveling steering column. Variable, controllable cab heating with air circulation stage and particle filter, automatic climate control

Options

- Active seat climatization
- Auxiliary heating system with timer
- Protective roof grating
- FOPS protective roof grating
- Radio with speakers
- Glass roof panel made from bullet-proof glass
- Sunblind for windshield

624E Technical data, equipment

ATTACHMENTS

Design	Decades of experience and the latest computer simulations guarantee the greatest degree of stability and longest service life
Boom	Box-type boom with basic length 14 m, 2 folds for transport. Adjust by 2 hoist cylinders with safety shutoff valves. Steel rope sheaves in the boom head
Options	<ul style="list-style-type: none"> ■ Auxiliary jib, for load ratings to 4.5 t ■ Load moment limitation for hoisting implementation: latest generation of load moment monitoring, display shows all important data, lifting limit switch, pressure relief valves, rope run-out safeguard ■ Up to 2x 2.5 m extension can be bolted in for 16.5 m and 19 m boom length ■ Roller mask for less wear and tear

UNDERCARRIAGE CRAWLER

Design	Very strong crawler undercarriage, with integrated, protected drive transmission. Rigid track width R25/240 or R25/215
Drive	Strong travel drive with axial piston hydraulic motor and directly attached automatically functioning brake valve and compact planetary gear on each running gear side
Parking brake	Spring-loaded multi-disk brake
Traveling gear	Maintenance-free tractor running gear with hydraulic chain tension, 600 mm flat or 600 mm 3-grouser base plates,
Speed	0 - 2.5 km/h
Options	<ul style="list-style-type: none"> ■ 700-mm 3-grouser crawler shoes

UNDERCARRIAGE MOBILE

Design	Strong mobile undercarriage with integrated 4-point claw support, steering axle as hydraulically locking pendulum axle. Pendulum axle cylinder with pipe-fracture safety valves MP26
Drive	All-wheel drive powered by an adjustable hydraulic motor with direct-mounted, automatically actuated brake valve and 2-stage power shift transmission. Strong 40 t planetary axles with integrated steering cylinder, 2-circuit multi-disk service brake.
Parking brake	Spring-loaded multi-disk brake
Tires	10.00-20, 8
Speed	0-7 km/h Tier I, 0-20 km/h Tier II

WINCH

The winches are driven via high-pressure-regulated adjustable hydraulic motors, thus there is always optimal pulling force speed control. Strong oil-bath planetary gear, low-maintenance.

Crane and free fall brakes are spring-loaded, maintenance-free, low-wear disc brakes running in the oil bath, oil-cooled. The driver is assisted by the special, continuously-variable free fall brake that also helps to protect the machine.

	Series
Winches	6 t
Rope winch (rated load) 1st layer	60 kN
Rope diameter	16 mm
Rope speed 1st layer	0 - 110 m/min

Options	<ul style="list-style-type: none"> ■ Depth indicating device ■ Rope tensioning pulley
---------	---

OPERATING WEIGHT

Mass	approx. 29.900 kg
	624 with 2 x 6 t free fall winches, basic boom 14.0 m, counterweight 5.8 t, 15 t bottom hook block, mobile undercarriage
	R25/215: 30.0 t (14 m boom)
	R25/240: 30.3 t (14 m boom)
Notice	The operating weight varies depending on the version and equipment selected.



624E Boom system

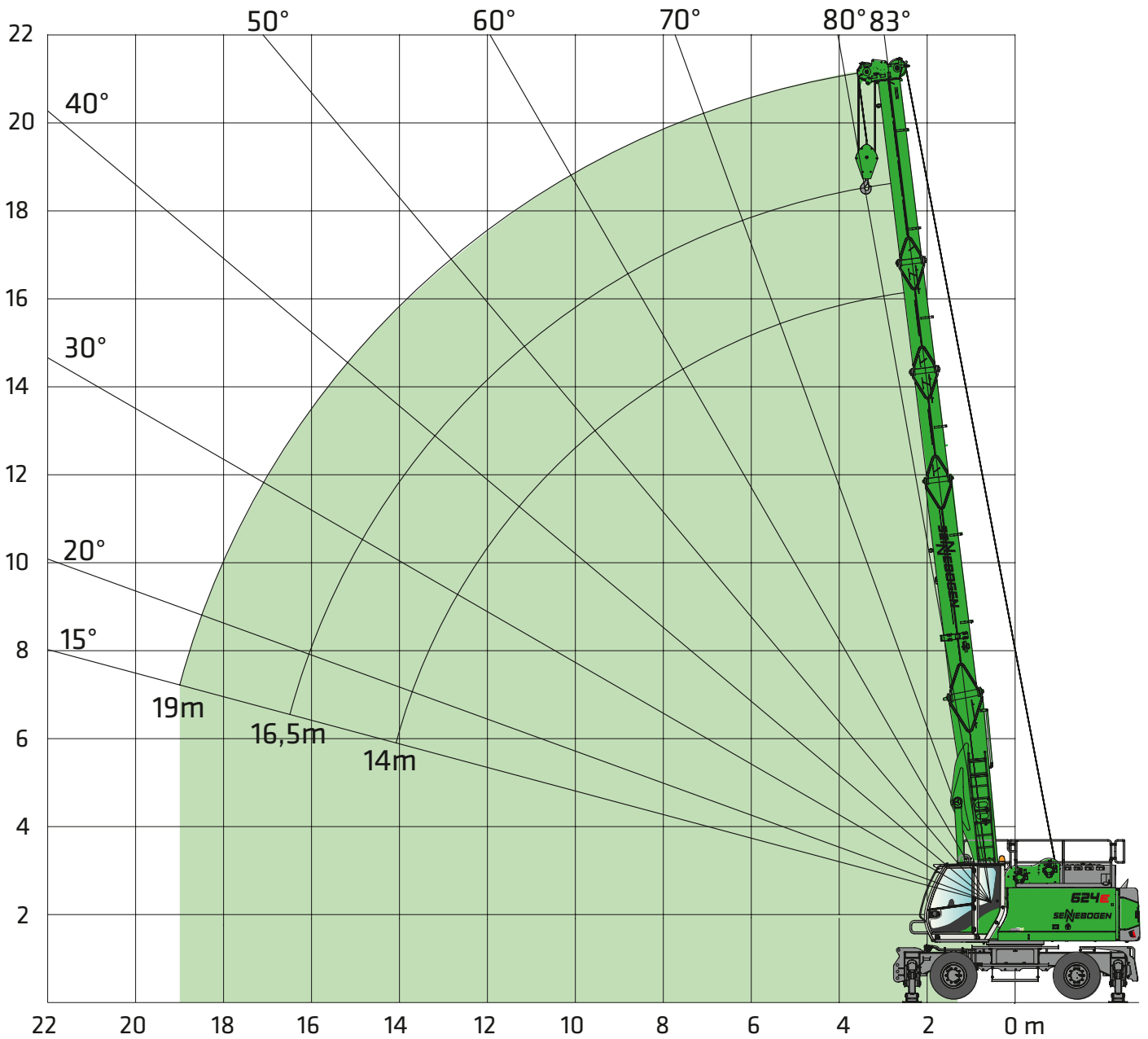

624E Load capacity in crane operation



Outreach [m]	Undercarriage								
	MP26			R25/240			R25/215		
	5.8 t			6.9 t			6.9 t		
Boom length [m]									
	14.0	16.5	19.0	14.0	16.5	19.0	14.0		
3.0	13.5			13.5	11.5/3.4	11.0/3.7	13.5		
4.0	12.0	11.5	11.0	12.0	11.5	10.8	11.0		
5.0	9.5	9.0	8.5	9.5	9.0	8.3	8.5		
6.0	7.9	7.4	6.9	7.8	7.2	6.6	6.8		
7.0	6.8	6.2	5.8	6.2	5.9	5.4	5.5		
8.0	6.0	5.4	4.9	5.1	4.8	4.5	4.5		
9.0	5.3	4.8	4.3	4.2	4.0	3.7	3.7		
10.0	4.8	4.3	3.8	3.6	3.3	3.0	3.1		
11.0	4.3	3.8	3.4	3.0	2.8	2.5	2.6		
12.0	3.9	3.5	3.0	2.6	2.4	2.1	2.3		
13.0	3.5	3.2	2.7	2.3	2.0	1.7	1.9		
14.0	3.0	2.8	2.5	2.0	1.7	1.4	1.7		
15.0	2.9/14.25	2.5	2.2	1.9/14.25	1.5	1.2	1.6/14.25		
16.0		2.2	1.9		1.2	1.0			
17.0		2/16.7	1.6		1.1/16.7	0.8			
18.0			1.4			0.6			
19.0	TAB.-Nr. 624M-80/1950/5.8/08.16		1.2	TAB.-Nr. 624R-80/1252/6.9/09.16		0.5	TAB.-Nr. 624R-80/1128/6.9/09.16		
20.0			1.2/19.1			0.5/19.1			
Number of strands	3	3	3	3	3	3	3	3	3

Comments:

1. The specified safe working load values apply for a level and stable stance of the machine.
2. The safe working load values are specified in tons (t) and apply for 360 degrees..
3. The safe working loads take the standards ISO 4305 Tab. 1+2 and the tilt angle method into account (angle of inclination 4°).
4. Deduct the weight of the load handling devices (hook, suspension gear) from the load ratings.
5. Load ratings must be limited or reduced when conditions are unfavorable, such as soft or uneven ground, slopes, wind, lateral loads, swinging loads, jerking or sudden stopping of the load, operator inexperience, driving with load.
6. Permissible rope pull per strand in crane mode for winch diameter 16 mm - 4,500 kg
7. Safe working load values apply for the SH boom (boom assembly in accordance with the operating manual).

Boom extension 2.5 m

Weight approx. 660 kg

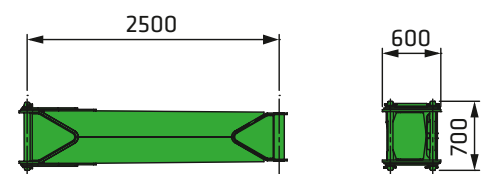

624E Grab equipment

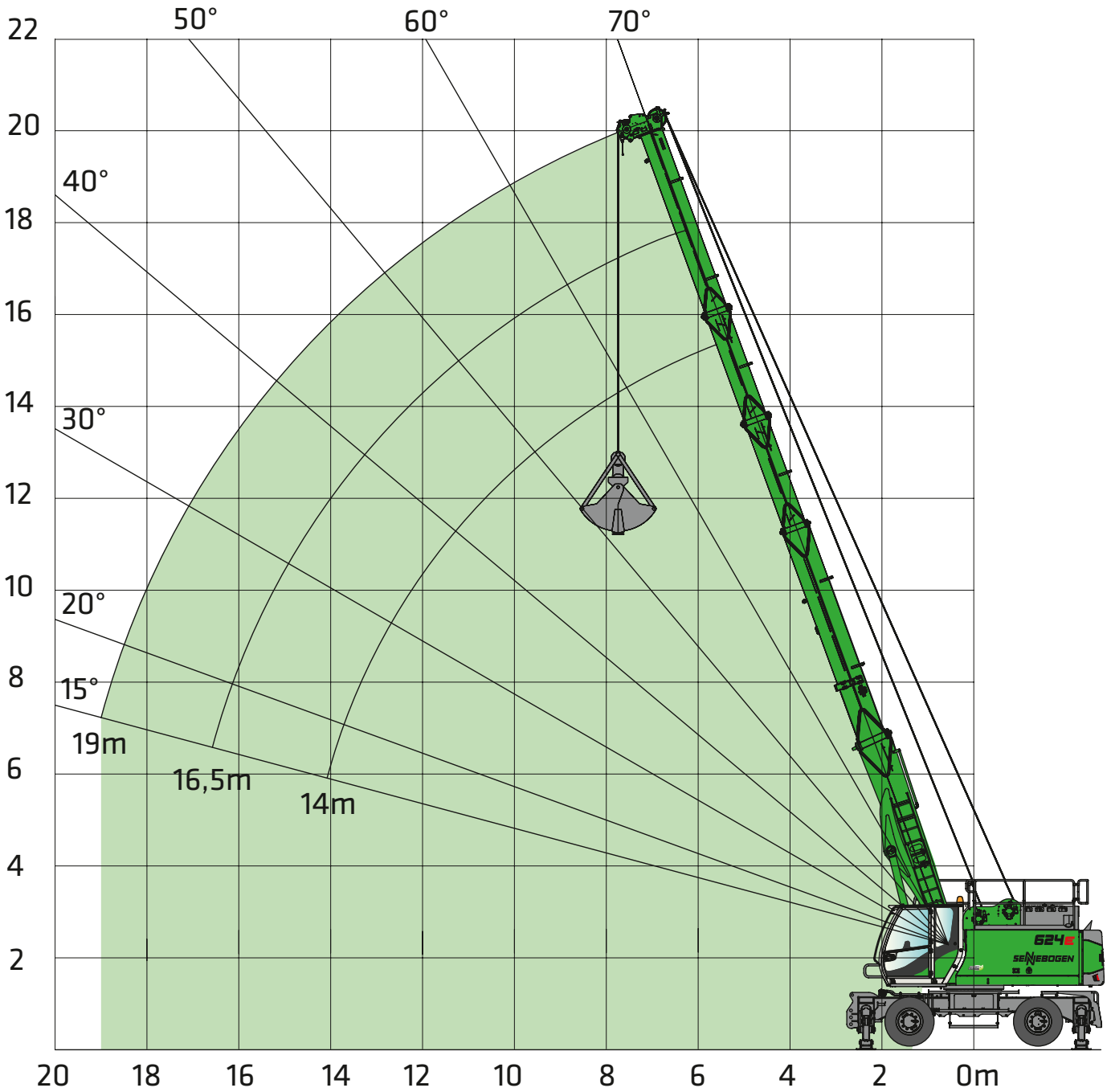

624E Load capacity in grapple operation



Undercarriage																					
Boom length [m]																					
Boom angle alpha [°]	14			16.5			19			14			16.5			19			14		
	R	H	t	R	H	t	R	H	t	R	H	t	R	H	t	R	H	t	R	H	t
	m	m	t	m	m	t	m	m	t	m	m	t	m	m	t	m	m	t	m	m	t
70	5.8	15.3	6.1	6.7	17.7	4.9	7.5	20.0	4.0	5.8	15.1	6.1	6.7	17.5	4.9	7.5	19.7	4.0	5.8	15.0	6.1
65	7.0	14.8	5.1	8.0	17.1	4.1	9.1	19.4	3.2	7.0	14.6	5.1	8.0	16.9	4.1	9.1	19.0	3.2	7.0	14.5	4.7
60	8.0	14.2	4.5	9.3	16.4	3.5	10.5	18.5	2.7	8.0	14.0	4.3	9.3	16.2	3.3	10.5	18.2	2.6	8.0	13.9	3.8
55	9.0	13.5	4.0	10.5	15.6	3.0	11.9	17.6	2.3	9.0	13.3	3.6	10.5	15.3	2.7	11.9	17.3	2.0	9.0	13.2	3.2
50	10.0	12.7	3.6	11.6	14.7	2.7	13.2	16.6	2.0	10.0	12.5	3.1	11.6	14.4	2.3	13.2	16.2	1.7	10.0	12.4	2.7
45	10.9	11.9	3.3	12.6	13.6	2.5	14.4	15.4	1.8	10.9	11.7	2.7	12.6	13.4	1.9	14.4	15.1	1.4	10.9	11.5	2.4
40	11.7	10.9	3.0	13.6	12.5	2.2	15.5	14.2	1.6	11.7	10.7	2.4	13.6	12.3	1.7	15.5	13.8	1.1	11.7	10.6	2.1
35	12.4	9.9	2.8	14.4	11.4	2.0	16.5	12.8	1.4	12.4	9.7	2.2	14.4	11.2	1.5	16.5	12.5	1.0	12.4	9.6	1.9
30	13.0	8.9	2.6	15.2	10.1	1.9	17.3	11.4	1.3	13.0	8.7	2.0	15.2	9.9	1.3	17.3	11.0	0.8	13.0	8.5	1.7
25	13.5	7.8	2.5	15.8	8.8	1.7	18.0	9.9	1.1	13.5	7.6	1.9	15.8	8.6	1.2				13.5	7.4	1.6
20	13.9	6.6	2.3	16.3	7.5	1.6	18.6	8.3	1.0	13.9	6.4	1.8	16.3	7.3	1.1				13.9	6.3	1.5
15	14.3	5.4	2.1	16.7	6.1	1.5	19.1	6.7	0.9	14.3	5.2	1.7	16.7	5.9	1.1				14.3	5.1	1.5

Comments:

- The specified safe working load values apply for a level and stable stance of the machine.
- The safe working load values are specified in tons (t) and apply for 360 degrees.
- The safe working loads apply for the maximum outrigger width / undercarriage track width.
- The specified safe working loads include the grapple weight and do not exceed 66.7 % of the tipping load
- For operation with a mechanical two-rope grapple and even load distribution on the closing and holding ropes, the safe working load is limited by the permissible rope tension or the maximum winch pulling force of a winch:

Winch pulling force [kN]	60
Rope diameter [mm]	16
Minimum tensile strength [kN]	213
Maximum safe working load in single-winch operation [t]	6.0
Maximum safe working load in two-winch operation [t]	9.1

624E Transport dimensions

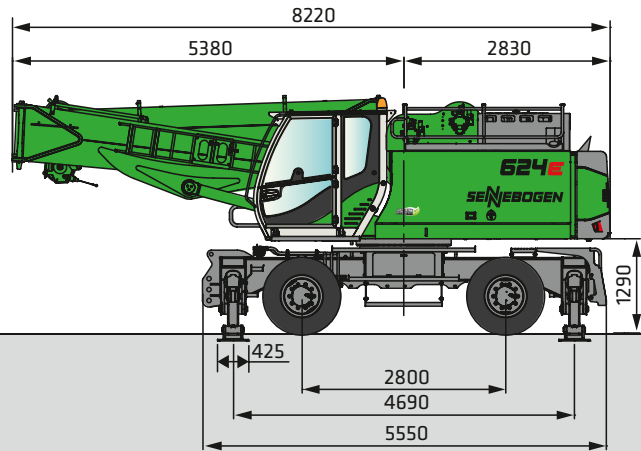
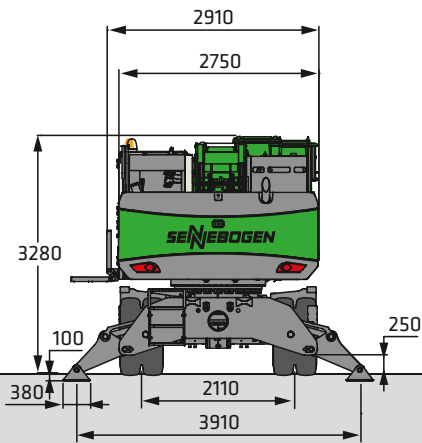

Mobile undercarriage MP26

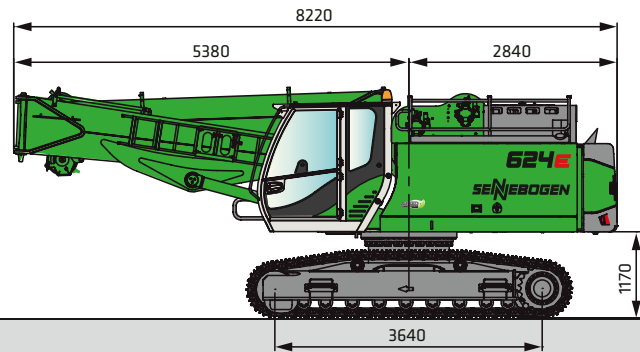
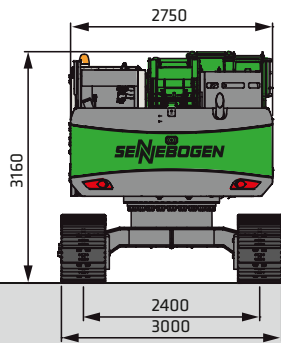

Crawler undercarriage R25/240

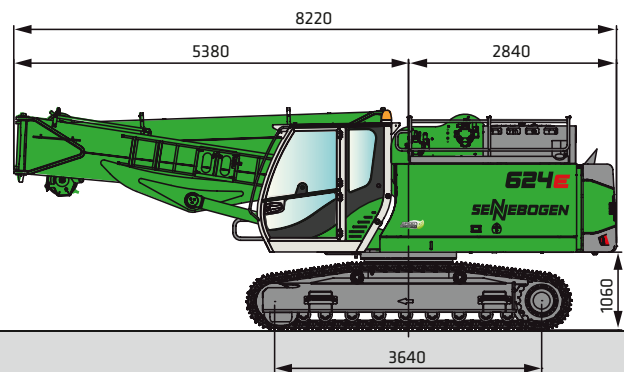
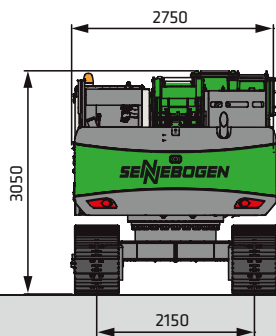

Crawler undercarriage R25/215

624E High mobility due to a simple folding mast system

Fold down the handrail at the ascent
Fold down uppercarriage railing

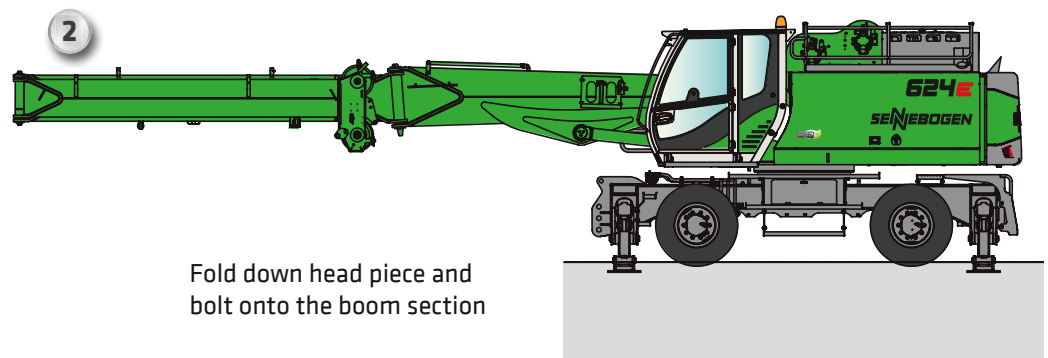
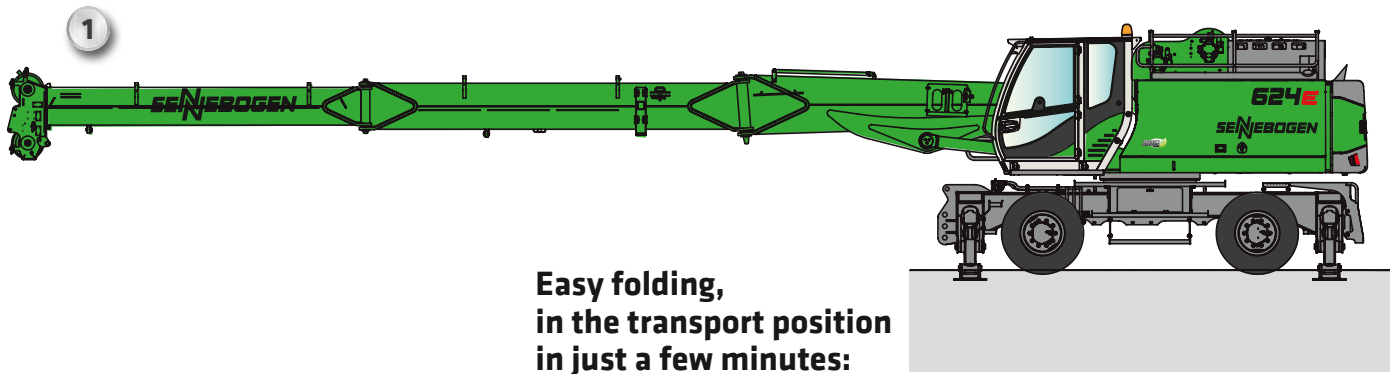

ADVANTAGES:

- Fast handling between different operation sites
- Ready for use in a short time thanks to the folding boom, no additional hoists required

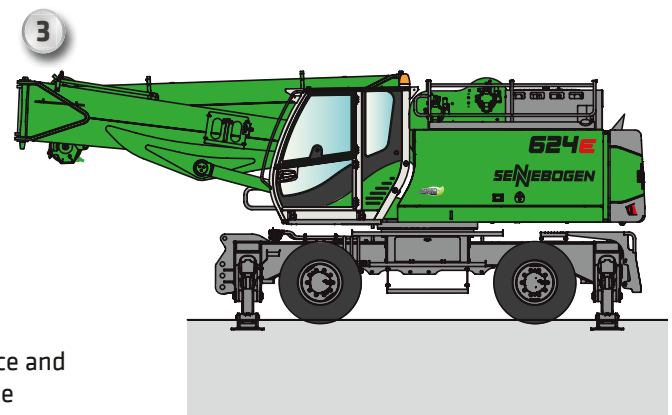

624E

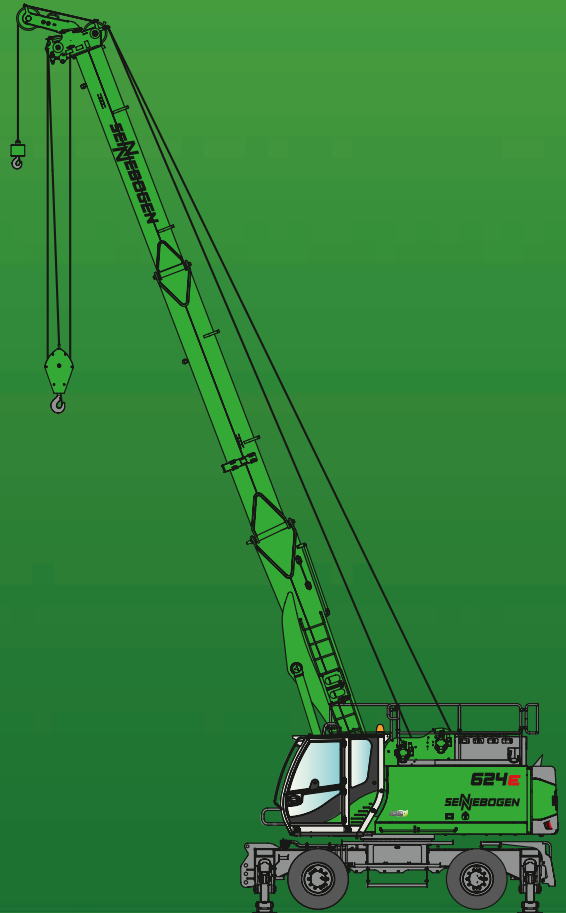

This catalog describes machine models, scopes of equipment of individual models, and configuration options (standard equipment and optional equipment) of the machines delivered by SENNEBOGEN Maschinenfabrik. Machine illustrations can contain optional equipment and supplemental equipment. Actual equipment may vary in a tolerance range depending on the country to which the machines are delivered, especially in regard to standard and optional equipment

All product designations used may be trademarks of SENNEBOGEN Maschinenfabrik GmbH or other supplying companies, and any use by third parties for their own purposes may violate the rights of the owners.

Please contact your local SENNEBOGEN sales partner for information concerning the equipment variants offered. Requested performance characteristics are only binding if they are expressly stipulated upon conclusion of the contract. Delivery options and technical features are subject to change. Errors and omissions excepted. Equipment is subject to change, and rights of advancement are reserved.

© SENNEBOGEN Maschinenfabrik GmbH, Straubing/Germany. Reproduction in whole or in part only with written consent of SENNEBOGEN Maschinenfabrik GmbH, Straubing, Germany.

The Sennebogen logo, consisting of the word 'SENNEBOGEN' in a bold, stylized, sans-serif font. The letters are white with a blue outline and are set against a dark blue rectangular background.

SENNEBOGEN
Maschinenfabrik GmbH
Sennebogenstraße 10
94315 Straubing, Germany

Tel. +49 9421 540-144/146
marketing@sennebogen.de

Order no. / Item no. 299115
624-E-021710-011910

GO FOR GREEN

www.sennebogen.com