

LIGHT BESCHOEIING

Serie 100

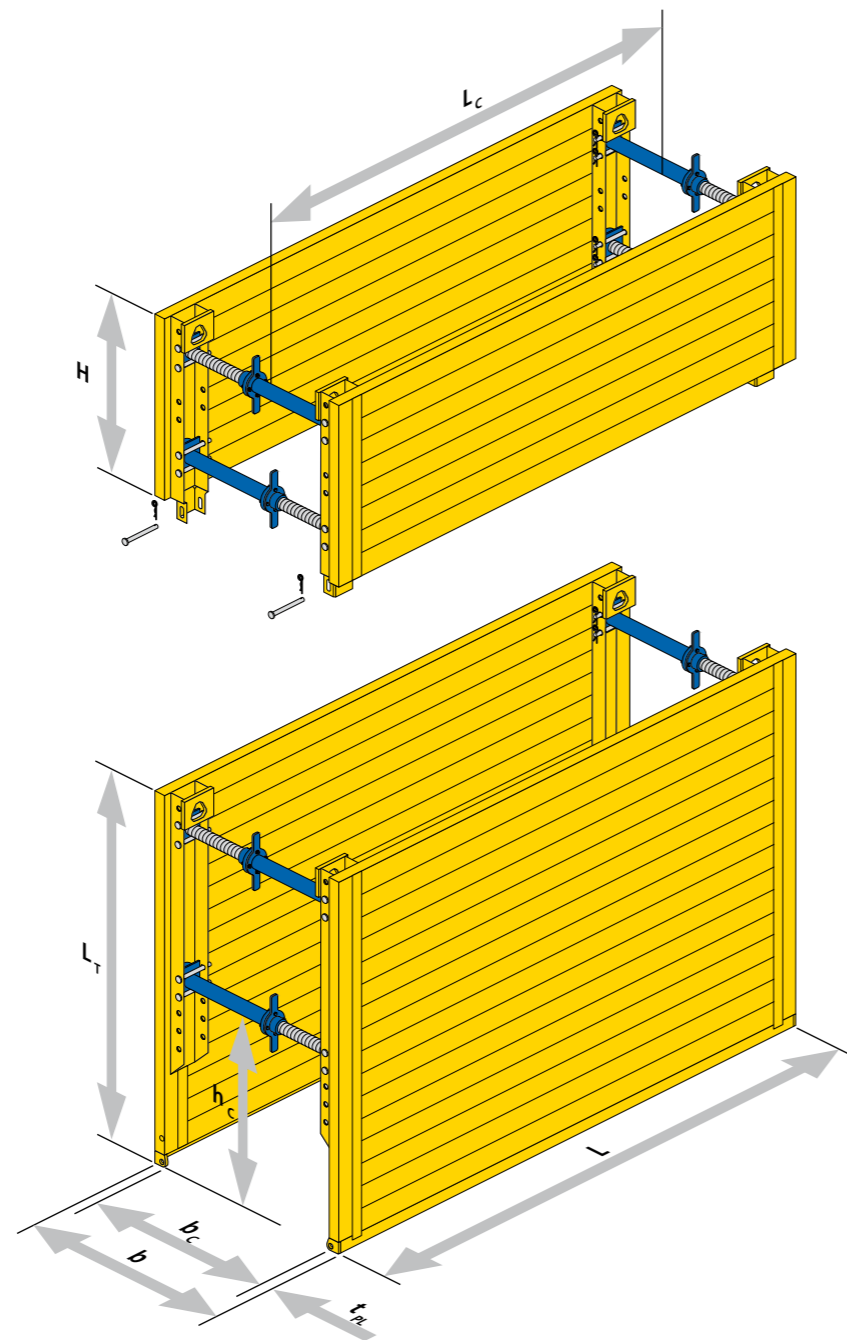

Platen $t_{PL} = 60\text{mm}$

plaatlengte L [m]	plaathoogte H [m]	vrije lengte L_c [m]	vrije hoogte h_c [m]	toelaatbare gronddruk [kN/m ²]	gewicht/box met stempels B [kg/box]
2,00	1,60	1,60	0,94	27,7	570
	2,00				670
	2,40				770
	2,60				830
	0,60				275
2,50	1,00	2,10	0,94	22,1	415
	1,60				655
	2,00				770
	2,40				890
	2,60				965
3,00	0,60	2,60	0,94	18,5	315
	1,00				470
	1,60				745
	2,00				875
	2,40				1010
3,50	2,60	3,10	0,94	15,3	1095
	0,60				355
	1,00				525
	1,60				830
	2,00				980
	2,40				1130
	2,60				1230
	0,60				395
	1,00				585

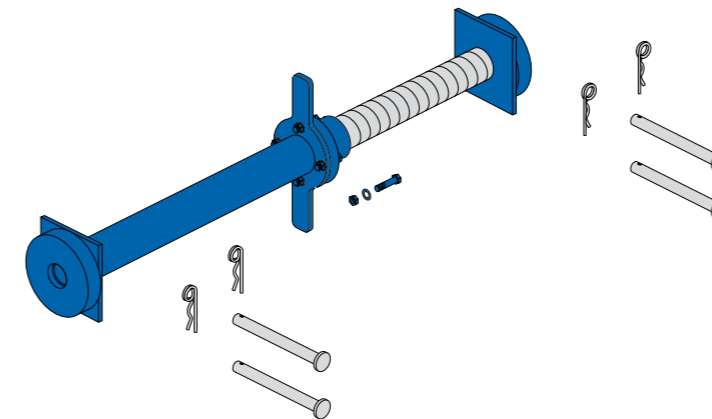

Light stempels

stempel type	werkbreedte b_c [m]		sleufbreedte b [m]		toelaatbare drukkracht [kN]	gewicht [kg]
	min.	max.	min.	max.		
A	0,53	0,73	0,66	0,86	160	14,2
B	0,71	1,07	0,84	1,20	147	16,9
C	1,05	1,65	1,18	1,78	124	20,9
D	1,50	2,10	1,63	2,23	107	23,6
E	1,88	2,48	2,01	2,61	92	25,8
F	2,48	3,08	2,61	3,21	69	29,3